

Released Form

Student Name: _____

Spring 2013
North Carolina
Measures of Student Learning:
NC's Common Exams
Physical Science



Student Booklet



Public Schools of North Carolina
State Board of Education
Department of Public Instruction
Raleigh, North Carolina 27699-6314

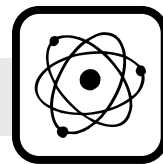

- 1 The graph below represents the motion of a cart.

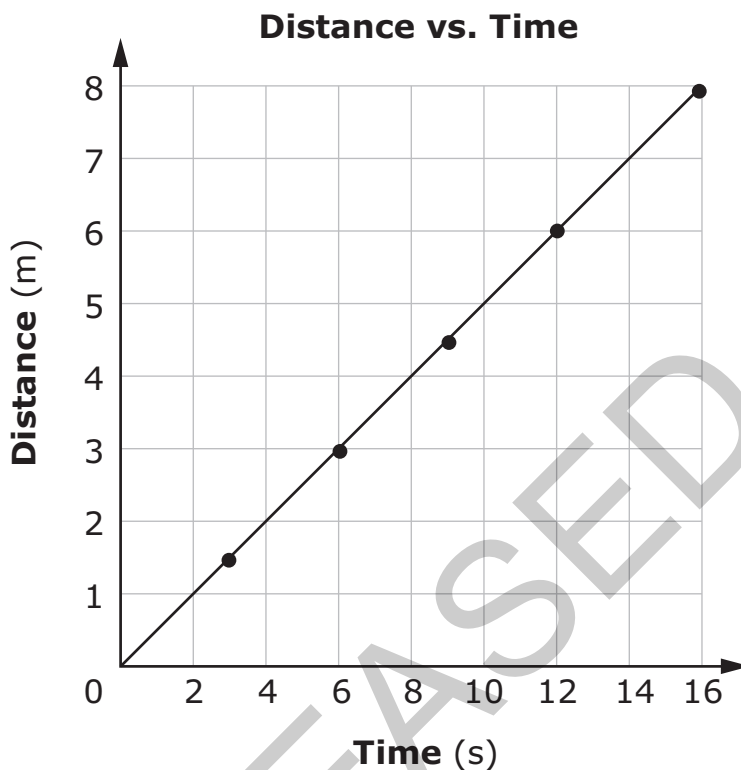

How does the speed of the cart compare when $t = 6$ s and $t = 12$ s?

- A The speed of the cart at 6 s is greater than when time equals 12 s.
- B The speed of the cart at 6 s is less than when time equals 12 s.
- C The speed of the cart is 0.5 m/s at 6 s and 12 s.
- D The speed of the cart is 2 m/s at 6 s and 12 s.

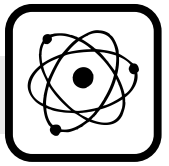

2 The chart below represents the change in velocity for four different trains.

Change in Velocity for Four Different Trains

Train	Initial Velocity	Final Velocity
W	60	91
X	39	68
Y	42	70
Z	65	94

If it took 5.38 s to reach the final velocity, which train had the greatest acceleration?

- A W
- B X
- C Y
- D Z

3 Why does a flat piece of notebook paper take longer to reach the ground than an identical piece of notebook paper crumpled into a ball?

- A The flat piece of paper has more mass.
- B The crumpled piece of paper has more mass.
- C The frictional force of air has more effect on the falling flat piece of paper.
- D The frictional force of air has more effect on the falling crumpled piece of paper.

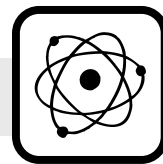

- 4 Why does the weight of an object change with increasing elevation on Earth?
- A The mass of the object decreases with higher elevation.
 - B The force of gravity acting on the object increases with higher elevation.
 - C The force of gravity acting on the object decreases with higher elevation.
 - D The mass of the object increases with higher elevation.
- 5 Which type of friction occurs when an eraser is rubbed across a sheet of paper?
- A static
 - B sliding
 - C rolling
 - D fluid
- 6 Two students pull on the opposite ends of a rope, but neither student is able to move the other. Which statement **best** explains why neither student is moved?
- A They each pull on the rope with the same amount of force, so the net force is zero.
 - B They each exert the same amount of friction against the ground, so the net friction is zero.
 - C Their forces are not balanced, but gravity keeps them from moving.
 - D The two students have the same mass.

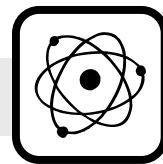

- 7 The diagram below shows a board on top of two bricks with a cylinder on top of the board.

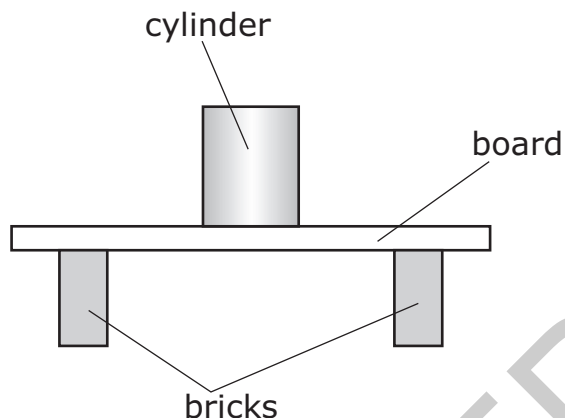

The board exerts an upward force of 50 N. Which **best** explains this situation?

- A The board has a weight of 50 N.
- B The cylinder has a weight of 50 N.
- C The combined weight of the two bricks is 50 N.
- D The combined weight of the bricks, board, and cylinder is 50 N.
- 8 Which is an example of a mixture?
- A iron filings
- B copper wire
- C bronze pipe
- D titanium plate

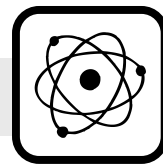

- 9 An element located at Group 18 and Period 4 would be classified as which type of substance?
- A a halogen
 - B a metalloid
 - C a lanthanoid
 - D a nonmetal

- 10 The chart below shows the density of five gases.

Density of Gases

Gas	Density (g/L)
helium	0.178
neon	0.900
argon	1.78
krypton	3.71
xenon	5.85

A gas has a volume of 4.52 L. If its mass is 8.05 g, what is the identity of the gas?

- A helium
- B neon
- C argon
- D krypton

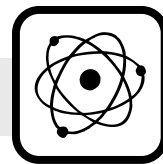

11 This graph shows the solubility curves for various ionic compounds.

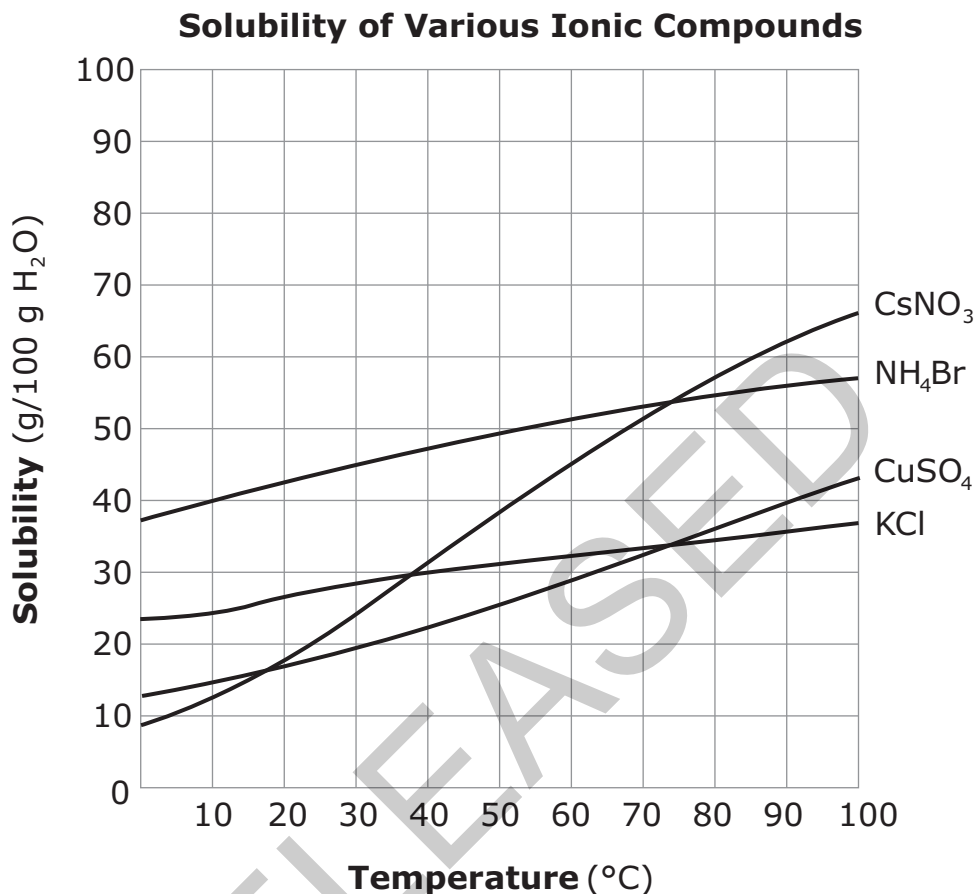

At which temperature does KCl have the same solubility as CuSO₄?

- A 18°C
- B 38°C
- C 73°C
- D 100°C

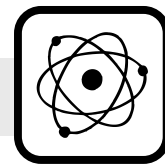

12 This is an electron dot diagram:

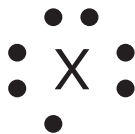

Which element is represented?

- A boron (B)
 - B phosphorus (P)
 - C sulfur (S)
 - D bromine (Br)
- 13 This diagram represents a neutral atom of boron-11.

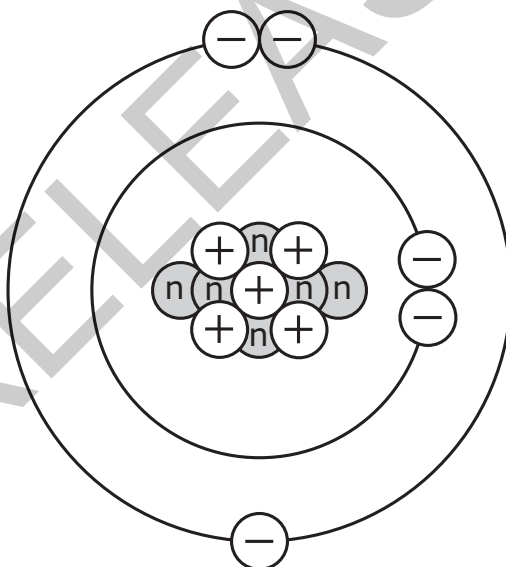

How many protons and neutrons does boron-11 have?

- A 11 protons, 11 neutrons
- B 11 protons, 0 neutrons
- C 6 protons, 5 neutrons
- D 5 protons, 6 neutrons

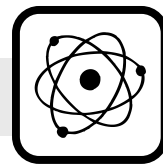

- 14 Which two elements have the same number of valence electrons?
- A C and O
 - B Na and Mg
 - C Cl and F
 - D Ga and Ge
- 15 Which of these elements is the **most** chemically reactive?
- A zinc (Zn)
 - B iron (Fe)
 - C potassium (K)
 - D germanium (Ge)
- 16 Some coins are alloys of zinc (Zn) and copper (Cu). Which type of bond forms these coins?
- A covalent
 - B hydrogen
 - C ionic
 - D metallic

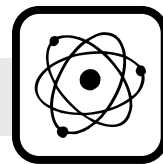

- 17 How can two different nonmetals form a compound?
- A by sharing protons
 - B by sharing electrons
 - C by transferring protons
 - D by transferring electrons
- 18 Which is the chemical formula for magnesium hydroxide?
- A $\text{Mg}(\text{OH})_2$
 - B MgOH
 - C MgOH_2
 - D Mg_2OH
- 19 Which is the correct name for the compound NaNO_3 ?
- A sodium nitrate
 - B sodium nitrous acid
 - C sodium nitrogen oxide
 - D sodium nitrogen trioxide

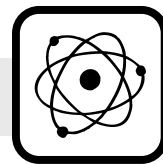

20 Which is a correctly balanced chemical equation?

- A $\text{CuCl}_2 + 2\text{Al} \rightarrow 2\text{AlCl}_3 + \text{Cu}$
- B $2\text{CuCl}_2 + \text{Al} \rightarrow \text{AlCl}_3 + 2\text{Cu}$
- C $2\text{CuCl}_2 + 3\text{Al} \rightarrow 3\text{AlCl}_3 + 2\text{Cu}$
- D $3\text{CuCl}_2 + 2\text{Al} \rightarrow 2\text{AlCl}_3 + 3\text{Cu}$

21 This equation represents an unbalanced chemical reaction:

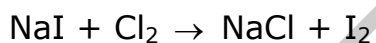

When the equation is balanced, which coefficient should be placed before NaCl?

- A 2
- B 3
- C 4
- D 5

22 This equation represents a balanced chemical reaction:

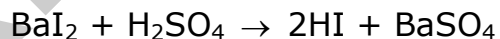

Which type of chemical reaction is represented?

- A double replacement
- B single replacement
- C decomposition
- D synthesis

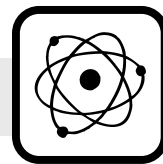

23 A scientist uses litmus paper to measure the pH of several different solutions. Which solution turns the litmus paper red?

- A NaOH
- B NaCl
- C HCl
- D NH₃

24 This equation represents a balanced neutralization chemical equation:

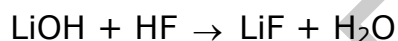

A solution of which compound has a pH greater than 7?

- A H₂O, because it is neutral.
- B HF, because it is an acid.
- C LiF, because it is a salt.
- D LiOH, because it is a base.

25 Which group is in order of increasing ability to penetrate an object?

- A alpha, proton, beta
- B alpha, beta, gamma
- C beta, proton, alpha
- D gamma, beta, alpha

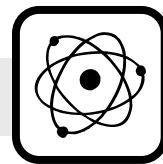

- 26 A 100-gram sample of radium-226 has a half-life of 1,600 years. How long will it take before there are only 12.5 grams of the radioactive radium-226 remaining?
- A 1,600 years
 - B 3,200 years
 - C 4,800 years
 - D 6,400 years
- 27 Why does a student's hand feel cold when holding an ice cube?
- A Heat flows from the ice cube to the hand.
 - B Heat flows from the hand to the ice cube.
 - C Cold flows from the hand to the ice cube.
 - D Cold flows from the ice cube to the hand.
- 28 What happens to the molecules in a pot of water as it is heated?
- A They move faster.
 - B They move slower.
 - C They lose thermal energy.
 - D They gain potential energy.

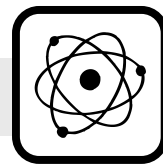

- 29 Two boxes, X and Y, are on a shelf 10 meters above the floor. Box X has a mass of 4 kg, and Box Y has a mass of 8 kg. Which statement **best** represents the relationship between boxes X and Y?
- A Box X and Box Y have no potential energy.
 - B Box X has less potential energy than Box Y.
 - C Box X has more potential energy than Box Y.
 - D Box X and Box Y both have 784 J of potential energy.
- 30 Which describes the kinetic energy of a ball in free fall?
- A The kinetic energy remains the same while the velocity increases.
 - B The kinetic energy decreases because the velocity increases.
 - C The kinetic energy increases because the velocity increases.
 - D The kinetic energy remains the same while the velocity decreases.
- 31 How do radio waves and visible light waves differ?
- A Radio waves have a shorter wavelength than visible light waves.
 - B Radio waves move faster than visible light waves.
 - C Radio waves have a lower frequency than visible light waves.
 - D Radio waves have more energy than visible light waves.

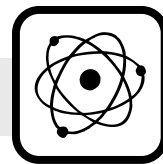

- 32 The diagram below represents a wave pattern.

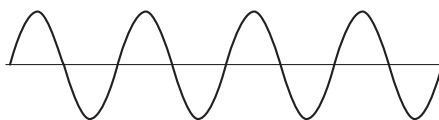

Which type of wave is represented?

- A longitudinal wave
 - B transverse wave
 - C sound wave
 - D primary wave
- 33 Object X and Object Y are rubbed together. Object X acquires a negative charge. What does Object Y experience?
- A a gain of protons
 - B a loss of protons
 - C a gain of electrons
 - D a loss of electrons

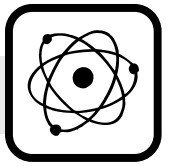

34 A positively charged ball is placed an equal distance between two charged objects (1 and 2). In which case will the positively charged ball move toward Object 2?

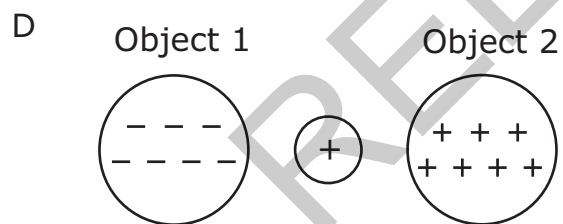
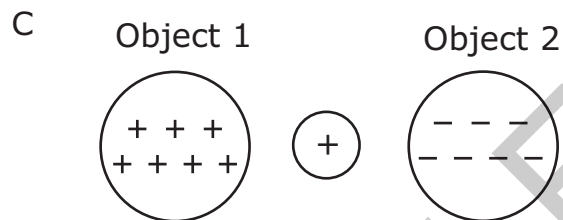
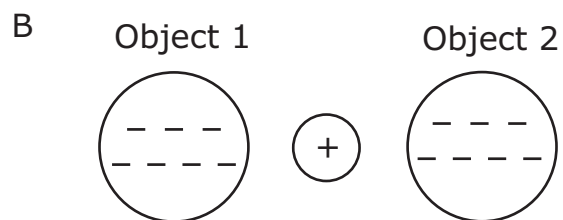
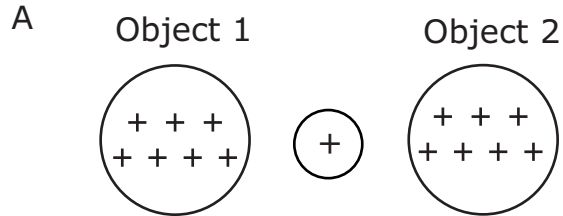

35 Which is a true statement about a series circuit?

- A All the current flows through every part of the circuit.
- B Every part of the circuit is positively charged.
- C The current through the circuit can take several paths.
- D Every part of the circuit is negatively charged.

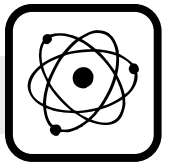

- 36 This diagram represents a circuit with three 20-ohm light bulbs. The battery is 10 volts.

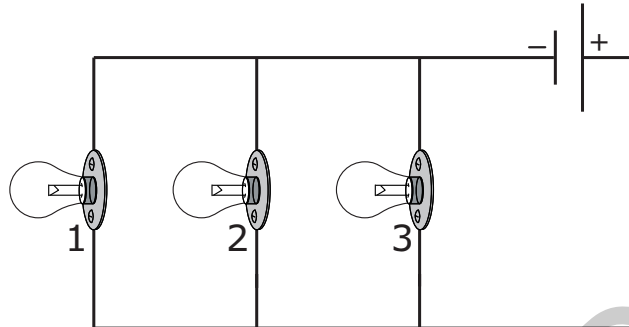

If light bulb 3 burns out in the circuit, what will happen to light bulb 1 and light bulb 2?

- A Light bulb 1 and light bulb 2 will work.
- B Light bulb 1 and light bulb 2 will not work.
- C Light bulb 1 will work, but light bulb 2 will not work.
- D Light bulb 1 will not work, but light bulb 2 will work.
- 37 A student wants to build a simple circuit. Which material would be used to design a circuit with the least amount of resistance?
- A long wires with a thin diameter
- B long wires with a large diameter
- C short wires with a thin diameter
- D short wires with a large diameter

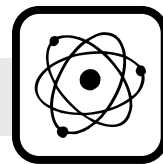

- 38 Two magnets are stuck end to end by a magnetic force. Which statement **best** describes these magnets?
- A The north poles of the magnets are attracted to each other.
 - B The south poles of the magnets are attracted to each other.
 - C The south pole of one magnet is repelled by the north pole of the other magnet.
 - D The north pole of one magnet is attracted to the south pole of the other magnet.
- 39 Which action will have the **least** effect on the strength of an electromagnet?
- A changing the amount of current
 - B changing the current's direction
 - C changing the number of wire loops
 - D changing the size of the metal core
- 40 In cars with electric door locks, electromagnets allow the doors to be locked and unlocked at the push of a button. Why is an electromagnet used for this kind of door lock?
- A Using electromagnets conserves electricity.
 - B Using electromagnets prevents static electric shock.
 - C Electromagnets can easily be turned off.
 - D Electromagnets can attract metals or nonmetals.

This is the end of the multiple-choice portion of the test.

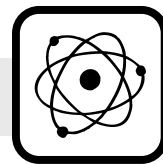

The questions you read next will require you to answer in writing.

1. Write your answers on separate paper.
2. Be sure to write your name on each page.

- 1 A student rides her bicycle to school, which is 6 km north of her home. After school, she rides to the grocery store that is 2 km north of the school.
- What is the total distance she travels from home to the grocery store?
 - For the student, her displacement from home to the grocery store is the same as her distance. How is this possible?
 - What could the student do to make her displacement different from her distance traveled?

RELEASED

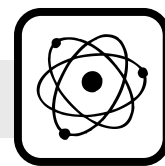

2 The graph represents the solubility curve for several substances in 100 g of water.

Solubility Curve for Various Compounds

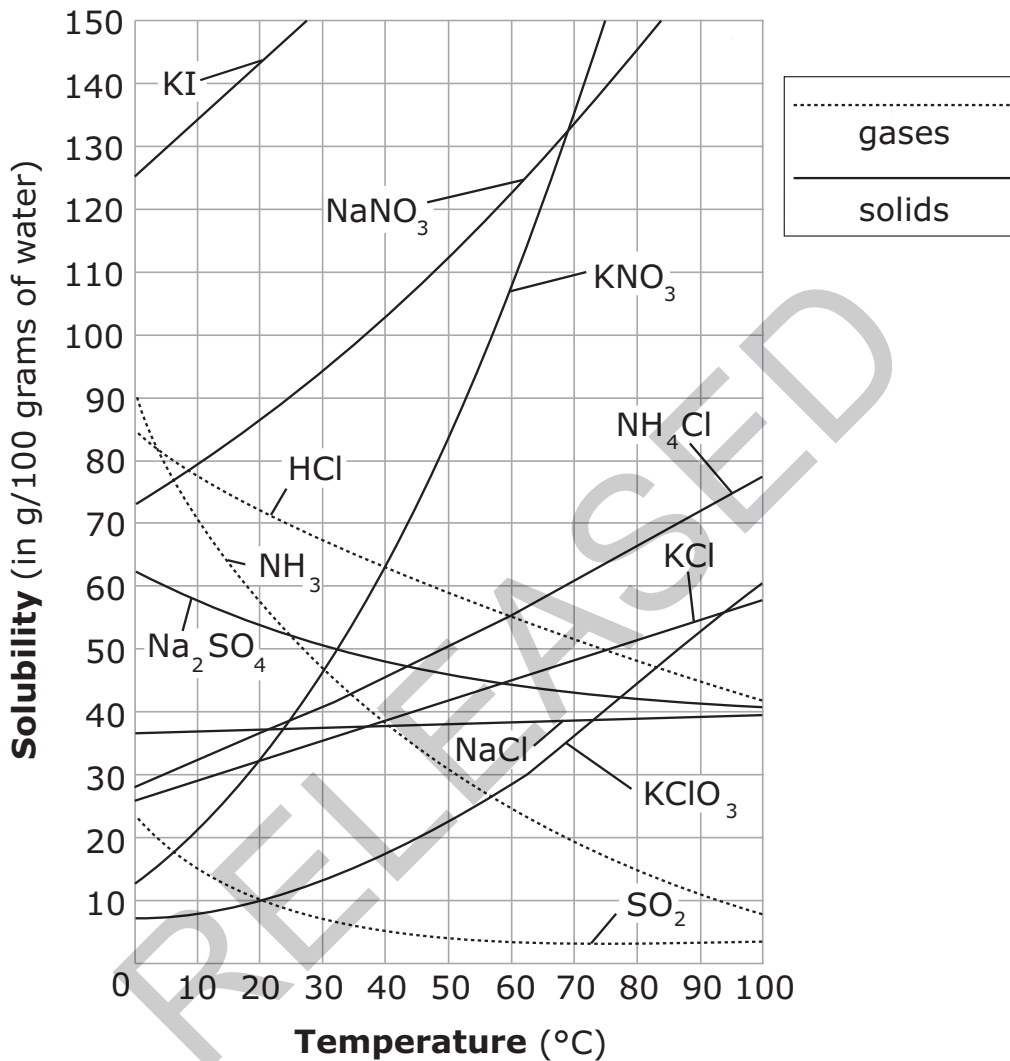

- Using the graph, determine which substance would be considered least soluble at 10°C. Explain your answer.

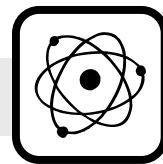

- 3 SONAR (Sound Navigation and Ranging) is often used to locate a ship below the surface of the ocean.
- What wave behavior is demonstrated by the use of SONAR?
 - Describe how SONAR can locate a ship below the surface of the ocean.

RELEASED

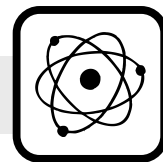

This is the end of the Physical Science test.

- 1. Look back over your answers.**
- 2. Put all of your papers inside your test book and close the test book.**
- 3. Place your calculator on top of the test book.**
- 4. Stay quietly in your seat until your teacher tells you that testing is finished.**

RELEASED

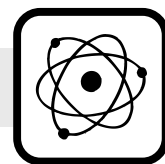

**Physical Science
RELEASED Form
Spring 2013
Answer Key**

Item number	Type	Key	Unifying Concept
1	MC	C	Forces and Motion
2	MC	A	Forces and Motion
3	MC	C	Forces and Motion
4	MC	C	Forces and Motion
5	MC	B	Forces and Motion
6	MC	A	Forces and Motion
7	MC	B	Forces and Motion
8	MC	C	Matter: Properties and Change
9	MC	D	Matter: Properties and Change
10	MC	C	Matter: Properties and Change
11	MC	C	Matter: Properties and Change
12	MC	D	Matter: Properties and Change
13	MC	D	Matter: Properties and Change
14	MC	C	Matter: Properties and Change
15	MC	C	Matter: Properties and Change
16	MC	D	Matter: Properties and Change
17	MC	B	Matter: Properties and Change
18	MC	A	Matter: Properties and Change
19	MC	A	Matter: Properties and Change
20	MC	D	Matter: Properties and Change
21	MC	A	Matter: Properties and Change
22	MC	A	Matter: Properties and Change
23	MC	C	Matter: Properties and Change

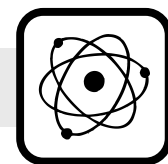

Item number	Type	Key	Unifying Concept
24	MC	D	Matter: Properties and Change
25	MC	B	Matter: Properties and Change
26	MC	C	Matter: Properties and Change
27	MC	B	Energy: Conservation and Transfer
28	MC	A	Energy: Conservation and Transfer
29	MC	B	Energy: Conservation and Transfer
30	MC	C	Energy: Conservation and Transfer
31	MC	C	Energy: Conservation and Transfer
32	MC	B	Energy: Conservation and Transfer
33	MC	D	Energy: Conservation and Transfer
34	MC	C	Energy: Conservation and Transfer
35	MC	A	Energy: Conservation and Transfer
36	MC	A	Energy: Conservation and Transfer
37	MC	D	Energy: Conservation and Transfer
38	MC	D	Energy: Conservation and Transfer
39	MC	B	Energy: Conservation and Transfer
40	MC	C	Energy: Conservation and Transfer
41	CR	Rubric	Forces and Motion
42	CR	Rubric	Matter: Properties and Change
43	CR	Rubric	Energy: Conservation and Transfer

Item Types:

MC = multiple choice

CR = constructed response